

DRAWING NUMBER  
DS509161

DATA SHEET

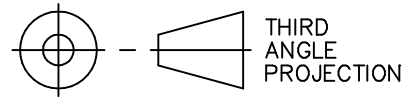

USED ON

D or CAT No

M.A/S.A

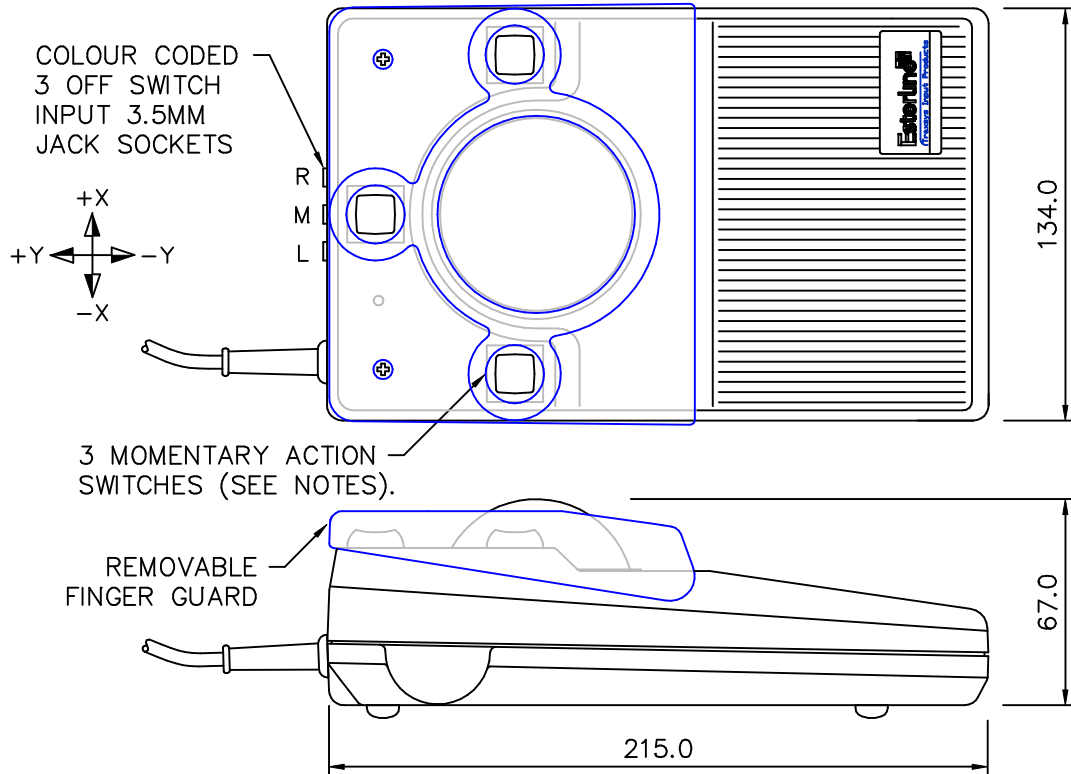

SPECIFICATION

CASE ~ MID GREY, A.B.S.  
 BALL ~  $\phi 2.5"$ , COLOUR: RED.  
 CABLE ~ 2 MTRS, PVC SHEATH,  
 COLOUR: WHITE.  
 CONNECTOR ~ USB SERIES 'A'.  
 (PS2 ADAPTER SUPPLIED).  
 RESOLUTION ~ 1080 EDGES/REVOLUTION.  
 SUPPLY ~ +5V D.C  $\pm 5\%$  @ 50mA MAX.  
 OUTPUT ~ UNIT WILL AUTODETECT TO EITHER PS/2  
 OR USB DEPENDENT ON HOST.

CONNECTION DETAILS

PIN	DESCRIPTION
1	+5V (RED)
2	- DATA (WHITE)
3	+ DATA (GREEN)
4	0V GND (BLACK)

LEFT BUTTON (YELLOW) & RIGHT BUTTON (BLUE) EMULATE RESPECTIVE USB BUTTONS.  
 MIDDLE BUTTON (GREEN):  
 1st PRESS ACTIVATES LATCHING "DRAG SWITCH" FACILITY.  
 2nd PRESS RELEASES THE ELECTRONIC LATCH.  
 ACTUATION OF LATCH INDICATED BY FLASHING LED.  
 PRESS & HOLD MIDDLE & RIGHT BUTTONS TO TOGGLE 'FAST MODE' ON & OFF.  
 PRESS & HOLD MIDDLE & LEFT BUTTONS TO TOGGLE 'LEFT HANDED' &  
 'RIGHT HANDED' BUTTON CONFIGURATION.

ISSUE	1	1A	1B	1C	2			
DATE	28.3.01	25.2.02	13.6.02	28.10.02	24.05.05			
CHANGE	NEW DWG	ECN0968	ECN1008	ECN1044	ECN1251			
MATERIAL	-		FINISH		-	TOL.	SCALE -	
						$\pm 1.0$	DIMS mm	

APP

CHKD

DRAWN  
R.HARNETT



Esterline Corporation.  
 Ringwood, Hampshire. BH24 1EU.  
 Tel: +44 (0) 1425 463100  
 Fax: +44 (0) 1425 463111  
 www.traxsys.com

TITLE  
 $\phi 2.5"$  ROLLER TRACKERBALL  
(TBDR/64/G1/UP2)

SIZE  
A4

DRAWING NUMBER  
DS509161